

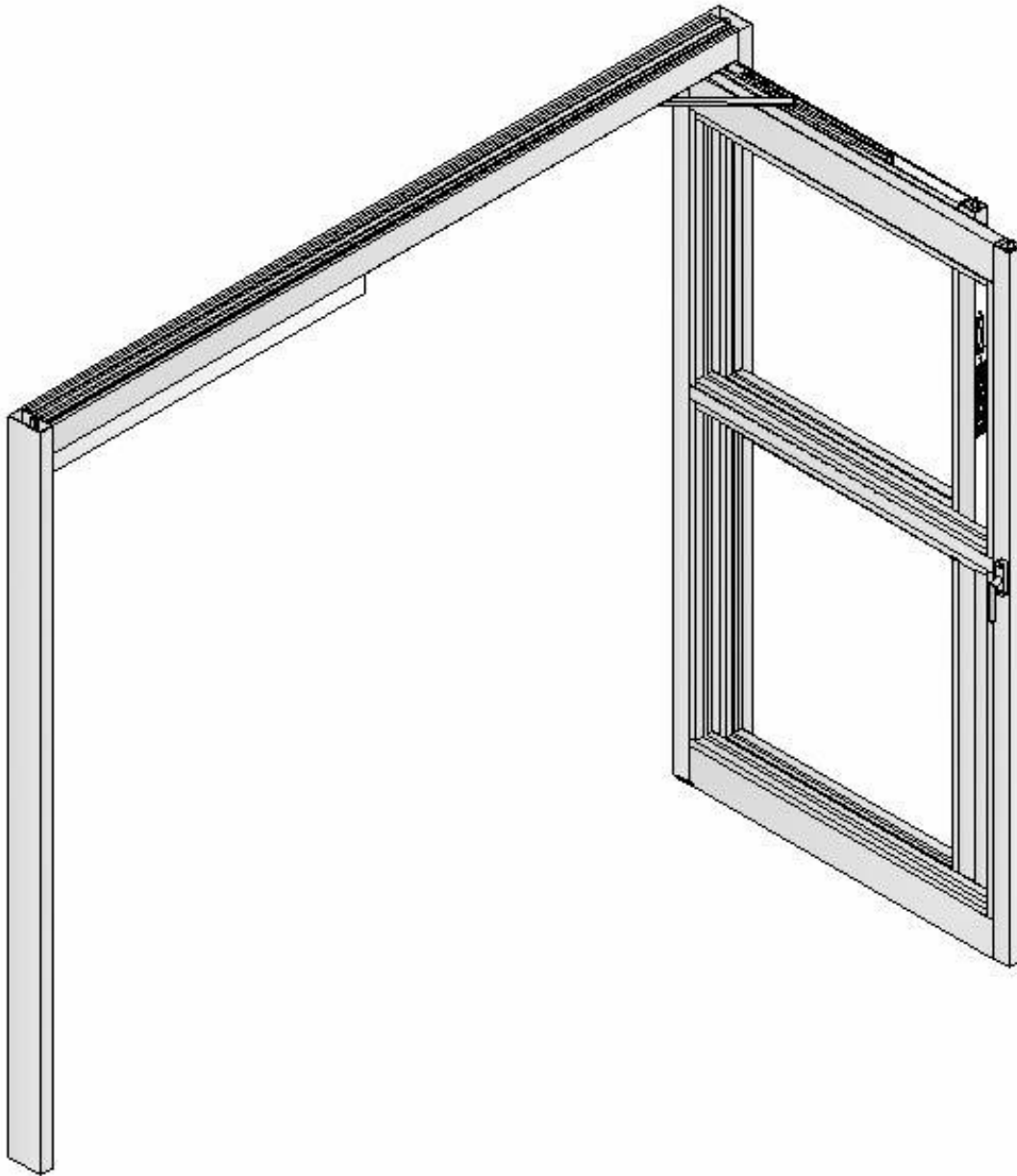

5900 Series ICU Sliding Door Installation Instructions



TRACKLESS ICU with POSITIVE LATCHING

INDEX

INDEX and HANDING.....	Page 2
PRODUCT INFORMATION, INVENTORY & TOOL LIST.....	Page 3
PREPARATION & FRAME ASSEMBLY.....	Page 4,5
THRESHOLD, BOTTOM GUIDE AND TRACKLESS INSTALLATION.....	Page 6
TRACKLESS TEMPLATE, DOOR & PANEL INSTALL.....	Page 7
DOOR & PANEL INSTALLATION (cont.).....	Page 8,9
SLIDING DOOR PRELOAD & BLOCKING ADJUSTMENT.....	Page 10

The sequence of installation and adjustment is in order, however, some sections will not apply in every case. Review this instruction manual and determine those sections that do not apply. If blueprints or drawings were provided, be sure to relate hand of slide and egress direction to the correct door location before assembly and standing of the package in the opening.

HANDING IDENTIFICATION

INTERIOR

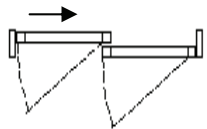

SX-SO shown
SO-SX opposite

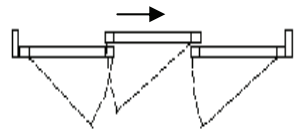

SO-SX-SO slide right shown
SO-SX-SO slide left opposite

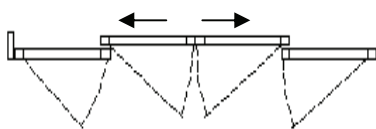

SO-SX-SX-SO
Bi-part

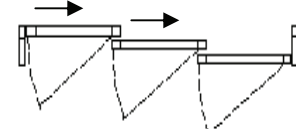

SX-SX-SO shown
SO-SX-SX opposite

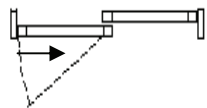

SX-O shown
O-SX opposite

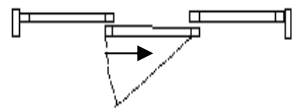

O-SX-O slide right shown
O-SX-O slide left opposite

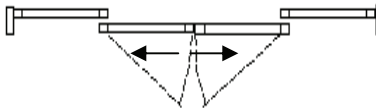

O-SX-SX-O
Bi-part

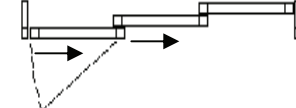

SX-X-O shown
O-X-SX opposite

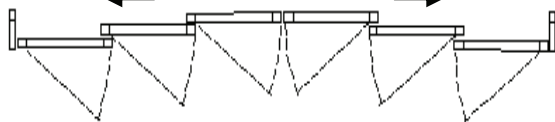

SO-SX-SX-SX-SX-SO
Bi-part

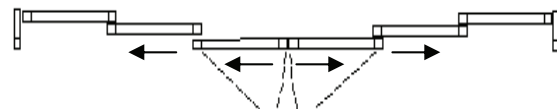

O-X-SX-SX-X-O
Bi-part

EXTERIOR



5900 Series ICU Sliding Door Installation Instructions

Product Information

The **record-usa** 5900 ICU-CCU sliding door was developed specifically for special care facilities, hospitals and surgical centers. A manual version **record-usa** highly successful automated entrance using all proven components which are accepted and in use world wide.

record-usa ICU-CCU doors are available in a wide range of sizes and configurations. Two, three and four panel packages are available as well as space saving telescoping model with three or six panels. Standard floor track may be replaced at the designers option by a trackless system providing an unbroken floor surface on all models.

The life of the door package is directly related to how carefully the installation is accomplished and how accurately the instructions are followed. Once the installation has been completed the door must be adjusted to the recommendations in this manual.

Inventory

Before beginning the assembly process, inspect all cartons for completeness of order. There should be at least six cartons for a standard bi-part package;

1. Header assembly
2. Side jambs
3. Door panels (number dependant on configuration)

Tool List

- | | |
|--|---|
| *Knife | *Hammer Drill |
| *4' or 6' Ladder | *Drill Bit set up to 3/8" & 1/4" and 5/16" Masonry bits |
| *4' level | *Allen Hex wrench set |
| *Hammer | *Channel lock pliers |
| *Tape measure | *Slip joint pliers |
| *Chalk line | *Flat and rat tail files |
| *Combination wrench set (1/4" to 7/8") | *Vise grip pliers |
| *Screwdrivers (#2 Philips) | *Shim material (shingles) |
| *Extension cord | *Caulking and gun |
| *3/8" drill | *Ratchet wrench set (1/4" to 7/8") |

Note: GLASS AND GLAZING ARE NOT INCLUDED IN THE PACKAGE.

THE GLAZING MATERIALS IN BOTH THE DOORS AND THE SIDELITES SHALL COMPLY WITH THE REQUIREMENTS IN THE AMERICAN NATIONAL STANDARD PERFORMANCE SPECIFICATIONS AND METHODS OF TEST FOR SAFETY GLAZING MATERIALS USED IN BUILDINGS, Z97.1.1975.

PREPARATION

Check the door opening for plumb and level. The floor must be checked for any high spots. The header can be used as the straight edge to detect any variation in the floor surface. Fill the low areas to make the floor level. (See view to the right)

Reminder: Always install from the highest point, providing the opening is to required height. If it is not, stop, find the contractor or owner to have opening modified or high spots of the floor removed.

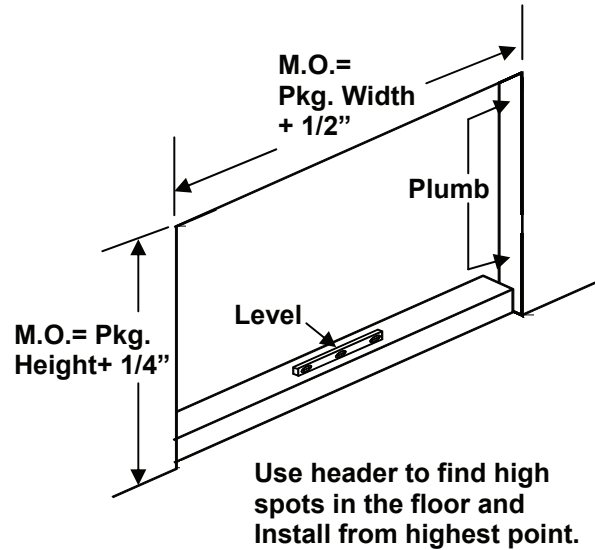

- Step 1. Clear a large enough area on the floor close to the opening in which the ICU is to be installed.
- Step 2. Place the cardboard from packaging on the floor, if necessary, to protect the finish of the header and jambs.
- Step 3. Place the header on the floor with the cover up and remove the cover.
- Step 4. Install jambs onto each end of header and secure with 1/4-20 x 1" Hex Head bolts provided, through access holes through end bracket into side jambs (See view at right).
- Step 5. Once the door frame has been assembled, place the frame at the opening on the floor so that the bottom of the jambs are at the proper location to stand. (See view next page).
- Step 6. Snap a chalk line across the opening where the jambs are going to be.

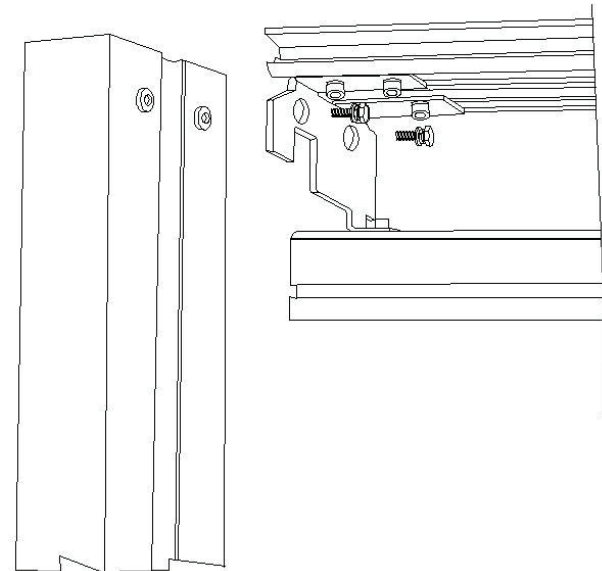

Before lifting the frame into place, check to make sure the cover side of the header will end up on the correct side of the opening. If the unit has sidelites that breakout, the cover will be interior; if the sidelites are fixed or the unit is surface mounted, the cover will be exterior.

FRAME / TRANSOM ASSEMBLY

If the unit is equipped with a transom, and the unit length is greater than 8', the frame must support the weight of the transom, glass, and an additional 130 lbs. For unit lengths up to 12' and 260 lbs. for units up to 16'. **Reminder:** Lay out the frame components and transom on the floor near the rough opening so as to allow lifting into the opening once assembled. **Note:** It is suggested that the frame members be prepped for attachment and attach with a screw; suggested size 10-24x1/2" flat head machine or sheet metal thread.

Do not allow over 8' of unsupported header. (The fixed panel is considered as suitable support for the header.)

Step 8. Lift door frame into the opening and set the frame plumb and square to the highest spot on the floor and position within the 4 1/2" dimension as needed. If there is room to raise the frame up even with the high spot in the floor, shim the bottom of the jambs to the high spot.

Step 9. Using wood shims, plumb and square the header and jambs in the opening. Secure the door frame to the opening with the appropriate type and number of fasteners for the size of the door package being installed. Fasten the header to the overhead every 36" or less using shims to insure being level across the entire opening.

Step 10. Using chalk line previously put down on floor to locate frame, identify the type guide system being used with the door package, (see page 5) and use to place bottom guide in line with the frame.

The standard guide for a fixed panel unit (O-SX-SX-O) is a G-rail with or without threshold; for full breakout units (SO-SX-SX-SO), the standard bottom guide is a pin guide track which is the same with or without threshold.

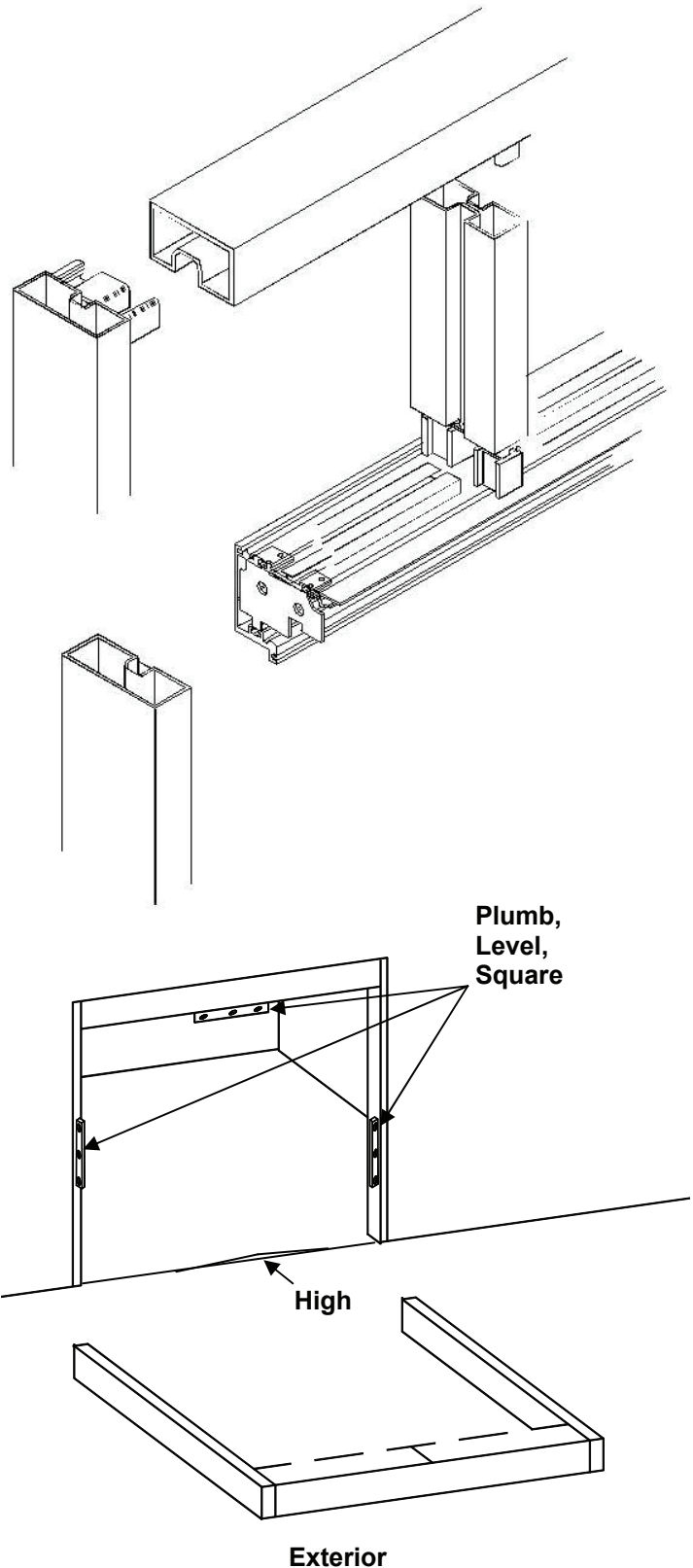

BOTTOM GUIDE INSTALLATION

The bottom guides must be installed level and in line with the frame for the door package to function properly. If the high spots referred to on page 4 were not corrected as indicated, proper location of the bottom guides will be extremely difficult. Correct high spots before continuing. Note: Be sure the floor portion of the guide system is placed in the non-sliding panel (sidelite) location.

Caution: If the door frame is not plumb, level, and square, do not secure the threshold to the floor. Recheck the frame, install the doors; then secure the threshold.

Together with the installation of a pin guide track, there will be a floor mounted bottom pivot to be installed for a full breakout sidelite. This must be accomplished before any attempt to hang doors.

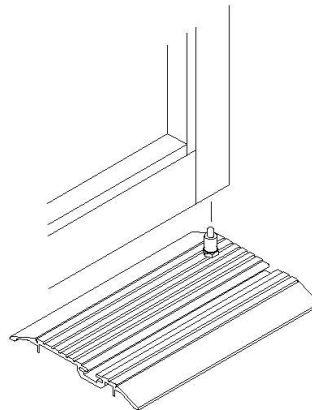

**SWING OUT ("SO") PANEL
TO PIN GUIDE TRACK**

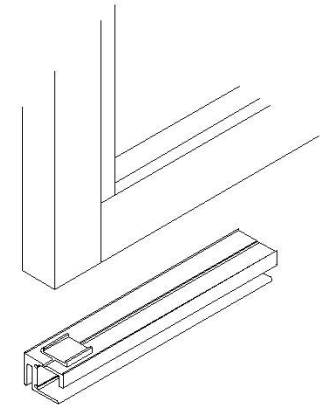

**FIXED ("O") PANEL TO
BOTTOM GUIDE RAIL**

TRACKLESS INSTALLATION

Standard floor track may be replaced at the designers option by a trackless system providing an unbroken floor surface on most models. A guide roller is attached to the swing out sidelite that extends under bottom rail of the sliding door which provides a link to guide the slide operation and to allow both panels to swing open in tandem.

Note: Doors can only swing from the full open position. Mechanical interlocking and an anti-breakout tube installed on the header prevents the door from swinging until it has been fully opened. Another reason for the sliding door having to reach full open is the engagement of the transfer pivot which provides a floor pivot point for the breakout feature of the sliding door, and also is designed to trap it in

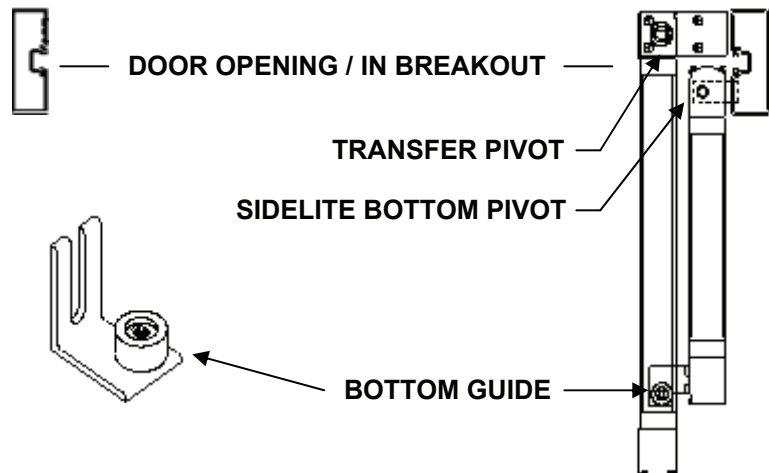
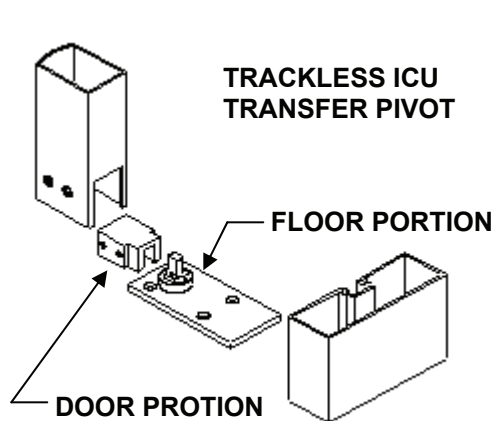

5900 Series ICU Sliding Door Installation Instructions

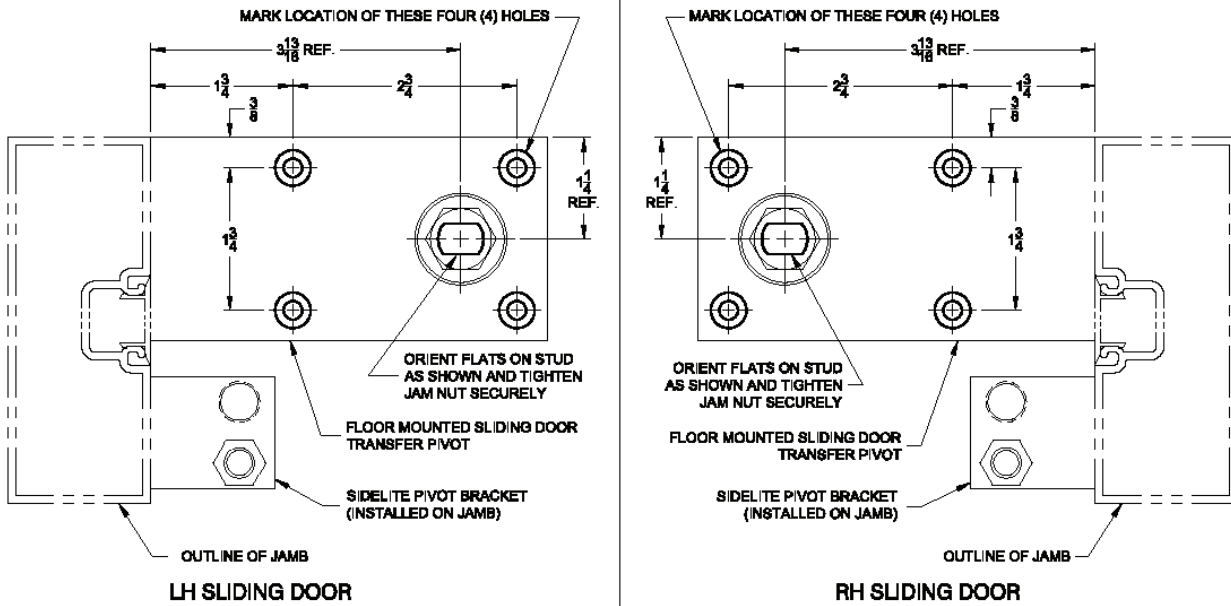

The floor portion of the transfer pivot will need to be positioned on the floor surface at the side jamb, using the dimensions shown in the view above, in line with the sliding door so that the door engages the pivot at full open. Secure to floor with screws and anchors provided.

SIDELITE AND DOOR ATTACHMENT / FIXED PANEL.....

If the package is a fixed panel configuration and the framing is up and the g-rail is in place and secure, proceed by taking the fixed panel and placing it on top of the g-rail, keeping it as close to the side jamb as possible. When the proper location is achieved, it will drop in place to interlock with the top of the g-rail. It should then be able to fit under the header to be flush with the face and come to rest against a lip which will have countersunk holes to drill through to fasten panel in place with screws provided.

Note: Before drilling and attaching, be sure fixed panel is pushed tight against the side jamb.

Next, the sliding door panel must have the bottom guide installed in the bottom of the pivot stile with hardware provided. Proceed by standing door so that bottom guide can be started in the end of the g-rail with the end cap removed. A panel not glazed can be easily lifted one end at a time to the height necessary to bolt through the catch assembly to the carrier assembly with provided bolts. If the panel is glazed, it may be necessary to place the door on blocking or use a pry bar to lift door to appropriate height. Adjust the door panel height so no rubbing or dragging occurs.

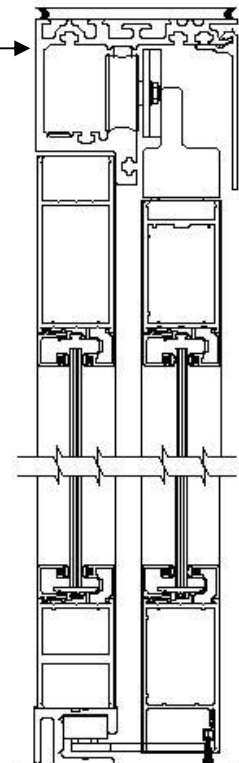

SIDELITE AND DOOR ATTACHMENT / SURFACE PIN GUIDE.....

If the package is a swingout panel configuration, with the framing and pin guide track located and secured in place, be sure that the bottom pivot to the sidelite (floor portion) has been installed to the track. The pin guide track will have a machined hole for locating the pivot pin, you then thread the pivot pin through the hole. Proceed by taking the swingout panel and confirm that the top and bottom pivots (door portion) are in place. Set the panel in place by locating to the bottom pivot and then drop the clevis pin, found in the header, in place when the sidelite is properly aligned. Next, the sliding door panel must have the bottom pin guide installed in the pivot stile. After hanging and attaching panel to carrier assemblies, go to the pin guide and adjust it to the proper height so that the door will slide in both directions without dragging. Then, lock it in place with the locking set screw.

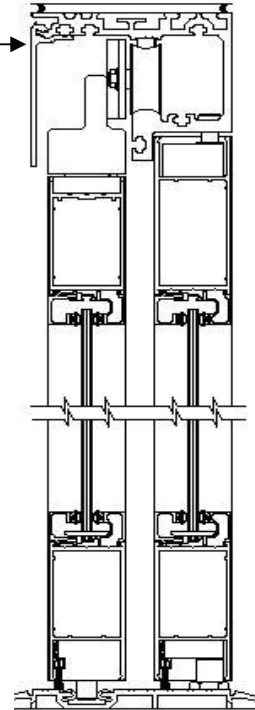

Sidelite and Door Attachment / Recessed Pin Guide.....

The procedure for assembly and hanging door panels on this package is the same with the exception of the pin guide track being recessed, so particular attention has to be given to the door adjustment height because of swinging the doors to the breakout position. If there is a rise in the floor when swinging the doors out, the appropriate adjustments will have to be made to accomplish this or the floor surface will have to be modified.

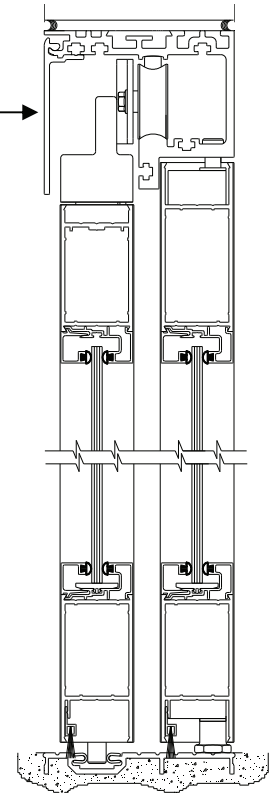

Sidelite and Door Attachment / Trackless..... →

After attaching the bottom door guide to the bottom leading surface of the sidelite and following the procedure previously explained for standing the swinging sidelite in place, proceed with hanging and attaching the sliding door to the carrier assemblies.

On the trackless units there is also a flush bolt in the top of the leading stile for securing the sidelite in the closed position. To engage the two doors together with the bottom guide, swing both door panels open 15 to 20 degrees to allow you to lift the leading end of the sliding door high enough to swing and set down on the bottom guide for engagement. Once this is achieved, proceed with checking to see that sliding door is adjusted for smooth operation with the bottom guide engaged.

Reminder: Take sliding door to the full open position and check to be sure that the anti-breakout tube is long enough to prevent the panel from being broke out without full engagement with the transfer pivot. Failure to do this could result in damage to the transfer pivot.

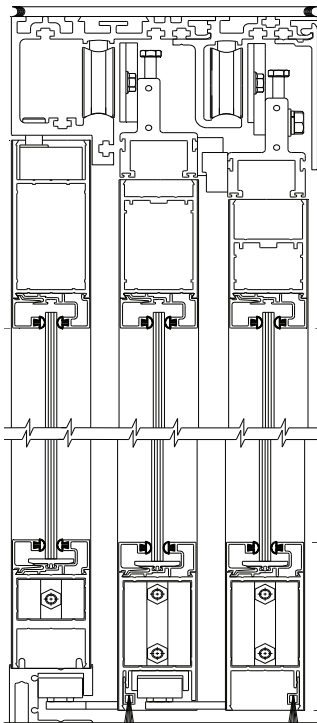
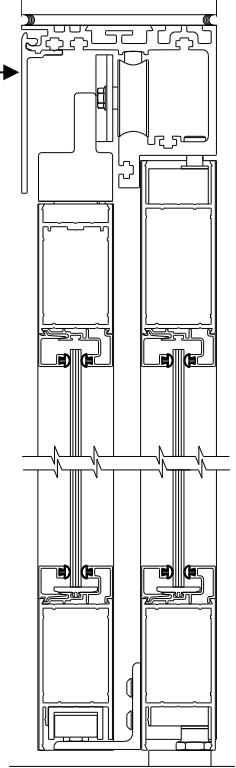

**“O” PANEL PKG.
3 OR 6 PANEL CONFIGURATION**

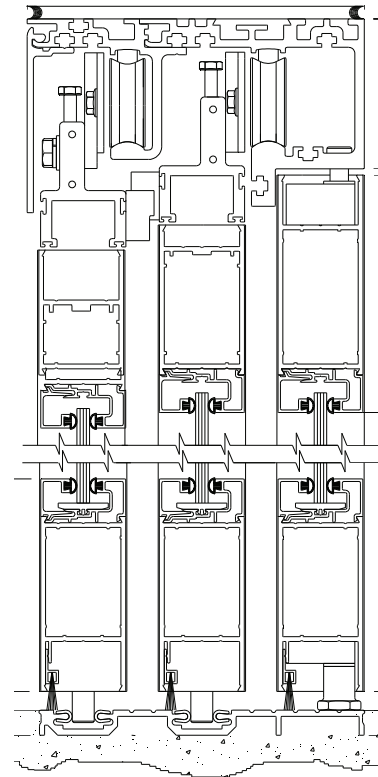

**“SO” PANEL PKG.
3 OR 6 PANEL CONFIGURATION**

To increase the “lift” of the breakout mechanism and prevent the door from dropping when broken out, perform the following instructions:

1. Insure the glass is blocked properly and in the locations shown at right. Please see location of Glass Jacking Screw to adjust and aid in blocking and preventing the door from dropping when “SX” Panel is in breakout.
2. Breakout the “SX” Panel 6”-8” as shown.
3. Using a 5/32” Allen hex wrench, loosen the two 1/4-20 Button Head socket cap screws located on the back of the vertical pivot stile 18” from the top.
4. Insert a 3/16” Allen hex wrench in the center hole between the two screws and tighten the concealed cap screw clockwise until snug.
5. Using your foot, apply force to the pivot stile below the screws in the direction of the lock stile, lifting the lock stile and the front of the panel.
6. Place a shim/wedge under the lock stile to remain elevated & re-tighten the two 1/4-20 Button Head screws. **Note:** Do not over tighten as this may cause distortion in the aluminum stile.
7. Remove shim/wedge and check for adequate lift support.

To adjust the force required to initiate a breakout, locate the ball catch at the top of the vertical lock stile and rotate it counterclockwise to increase the force required.

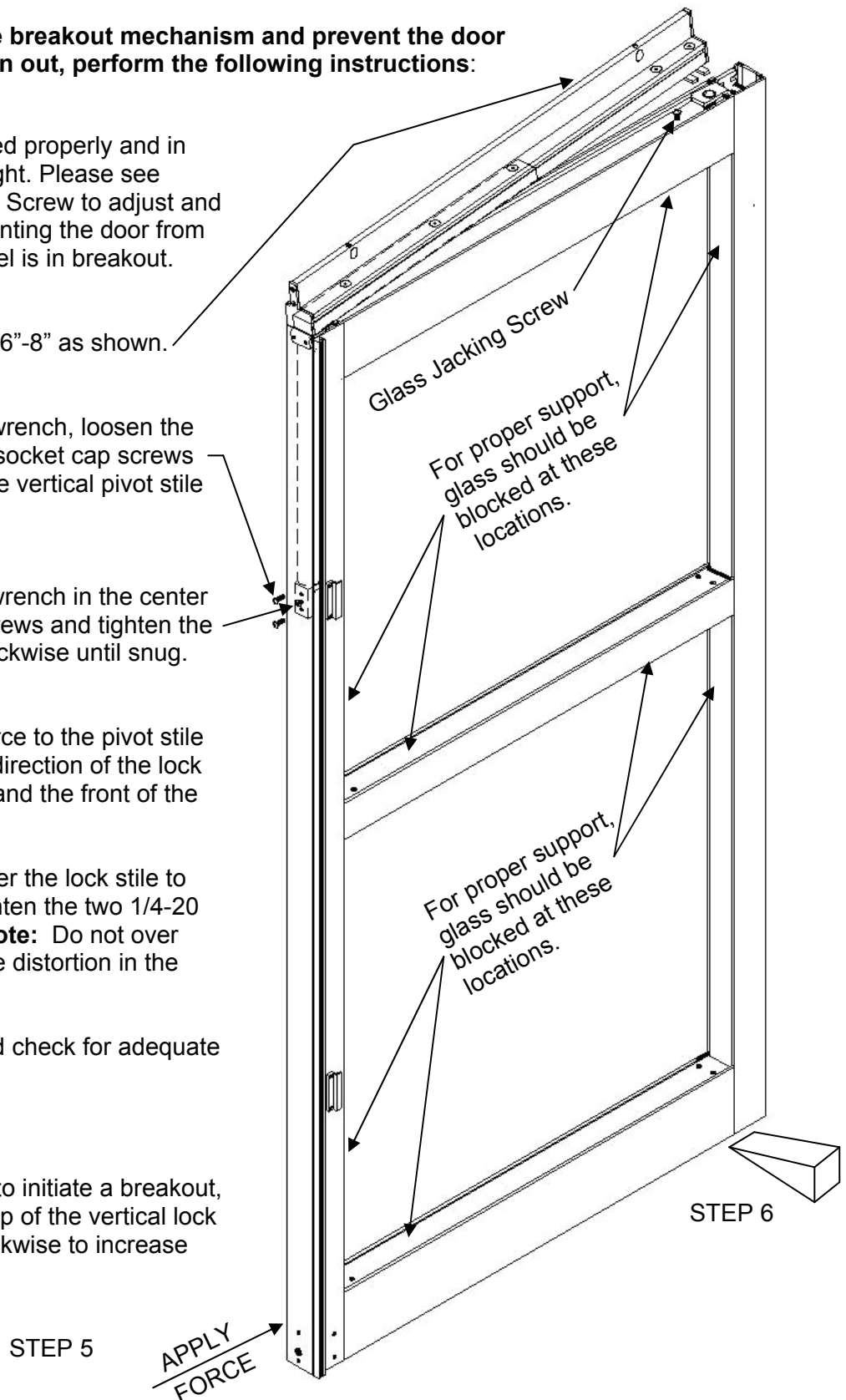

Positive Latching

Positive Latch Parts list:
One pair of handles (taped to door panel or in with accessories)
Strike bracket - jamb mounted
Bumper Pad - jamb mounted under bracket
Machined End Cap - Catch mounted

1. Cut tie-wrap holding mechanism in place in latch stile of door
2. Install handles to latch stile of door where prepped insuring engagement of mechanism each side. Be sure mechanism is turned towards heel of stile to install handles.
3. Before sliding door to the latch position, remove the upper & lower access plates in nose of latch stile; upper to see how & if the mechanism is moving far enough for a release, and the lower for adjusting mechanism for a good release.
4. After adjusting door height and squaring to frame, move door panel slowly to close position to check for strike bracket passing thru machined end cap into catch. Strike bracket may need adjusted up or down in the jamb.
5. It may now latch, so check to see if working the handles will release door to slide open.

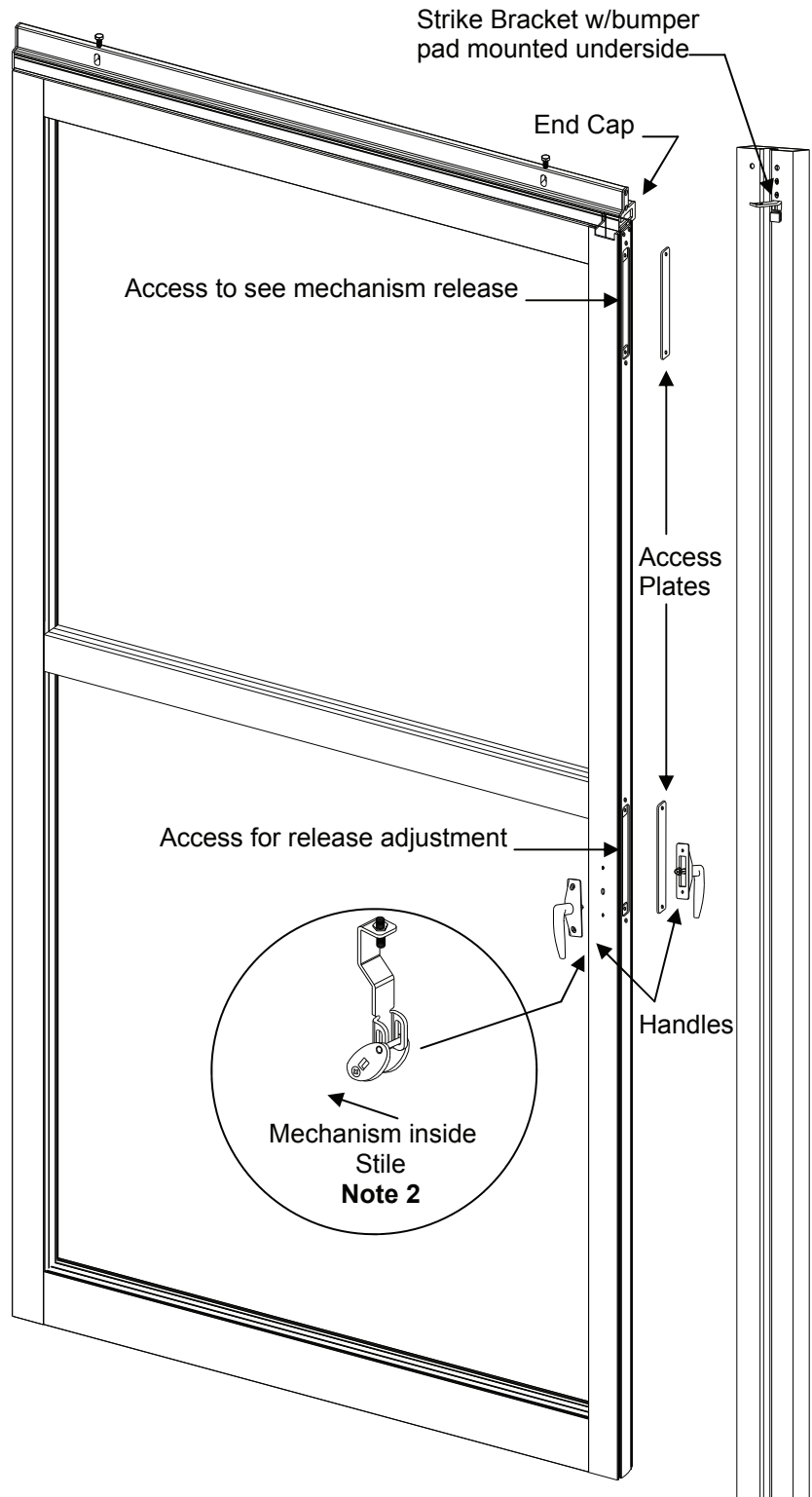

TELESCOPE ICU ASSEMBLY RH (SX-SX-SO) TRACKLESS (SHOWN)

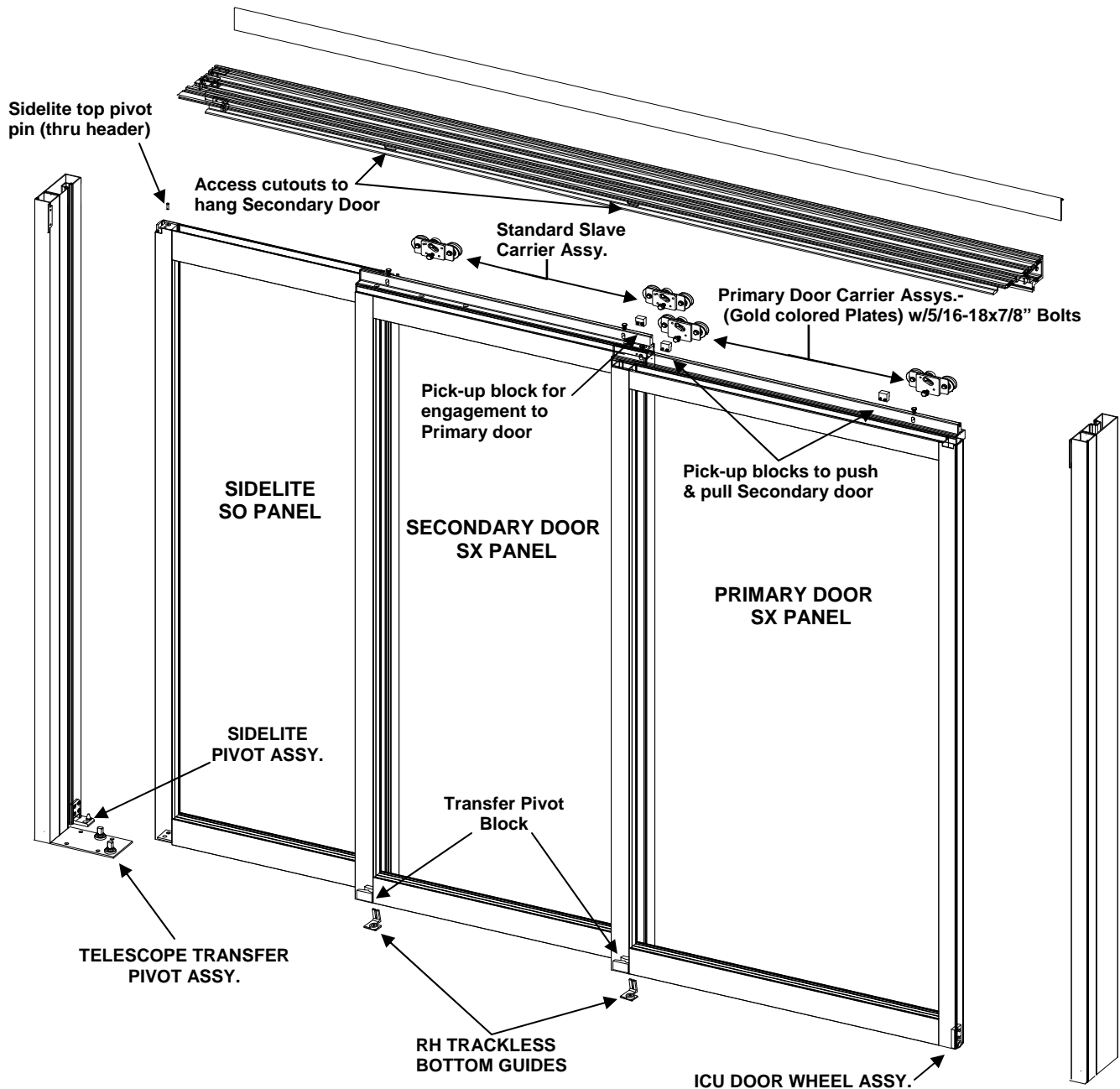

After installing Header and Frame level, plumb and square, proceed with locating and installing transfer pivot assembly to floor next to pivot/side jamb. Continue by installing sidelite on bottom pivot pin and then dropping top clevis pin through header into bushing with top of sidelite in position. Next, have Secondary SX Panel in position engaged to bottom guide assembly attached to sidelite to channel under the door and locate carriers and slots in top catch to cutouts in header to access and bolt in position. The remaining door or Primary SX Panel should then be engaged to bottom guide assembly attached to Secondary SX Panel to channel under the door and proceed to bolt to Primary Door Carrier Assemblies. During this procedure be sure the pickup blocks are installed and that the block on Secondary Door is in between the location of the blocks on the Primary Door for proper engagement and movement of the doors. If there is Positive latching, refer to page 11.